

12 11 10 9 8 7 6 5 4 3 2 1

H
G
F
E
D
C
B
A

H
G
F
E
D
C
B
A

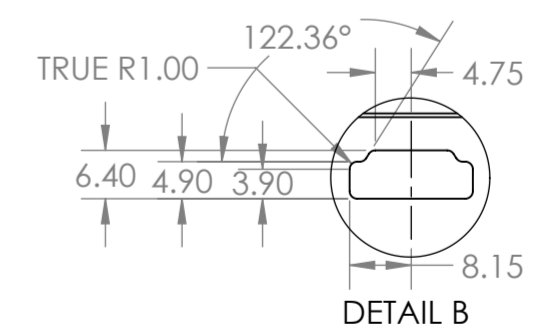
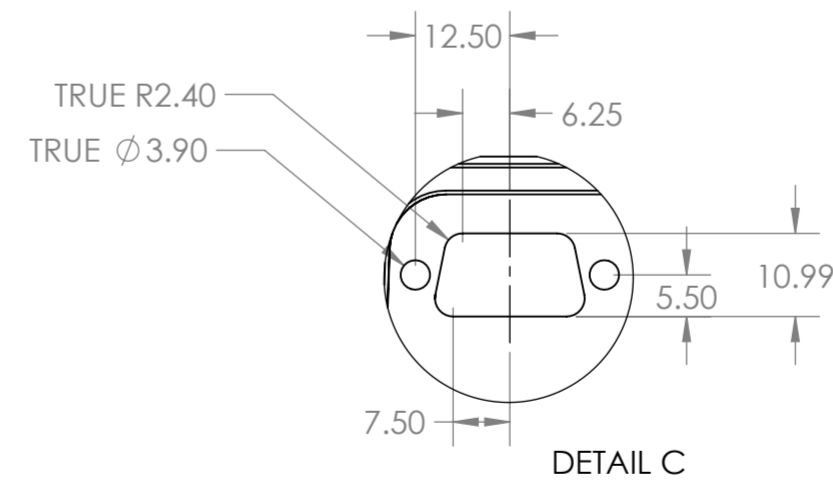
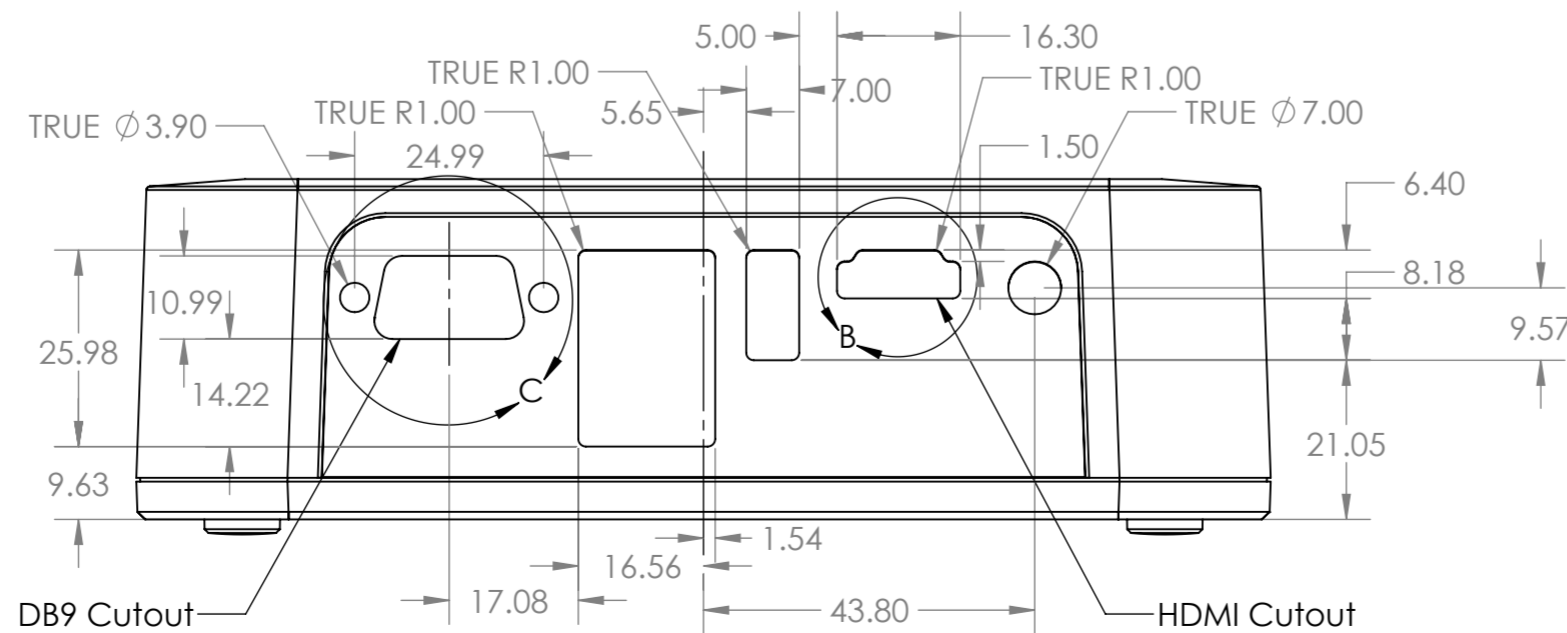
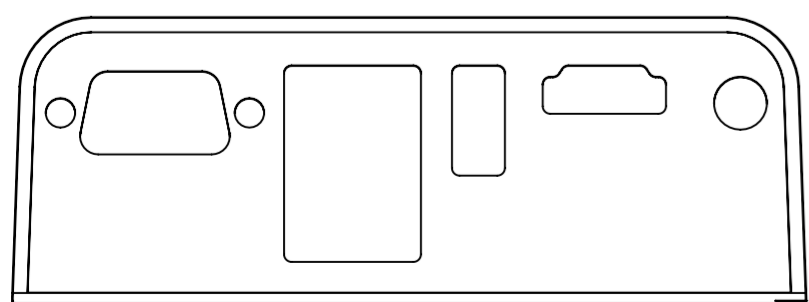
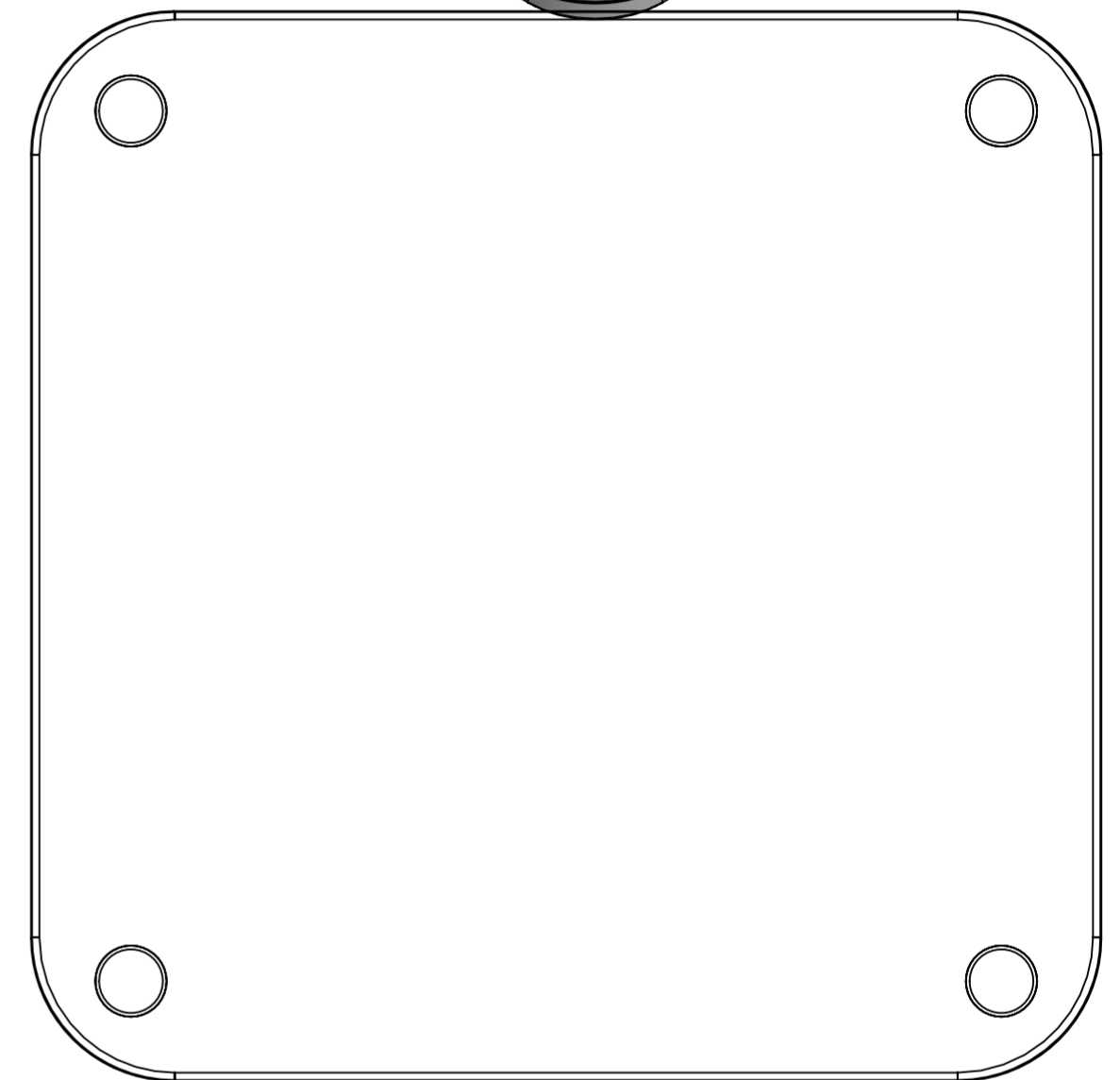
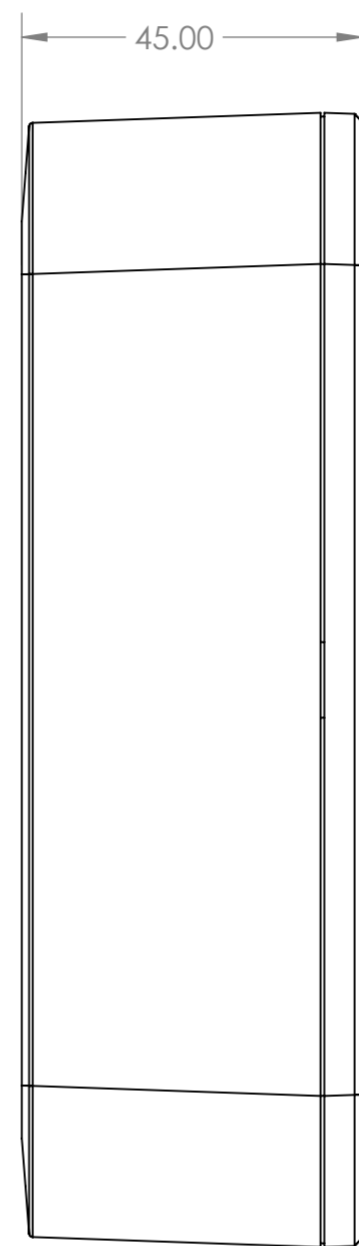
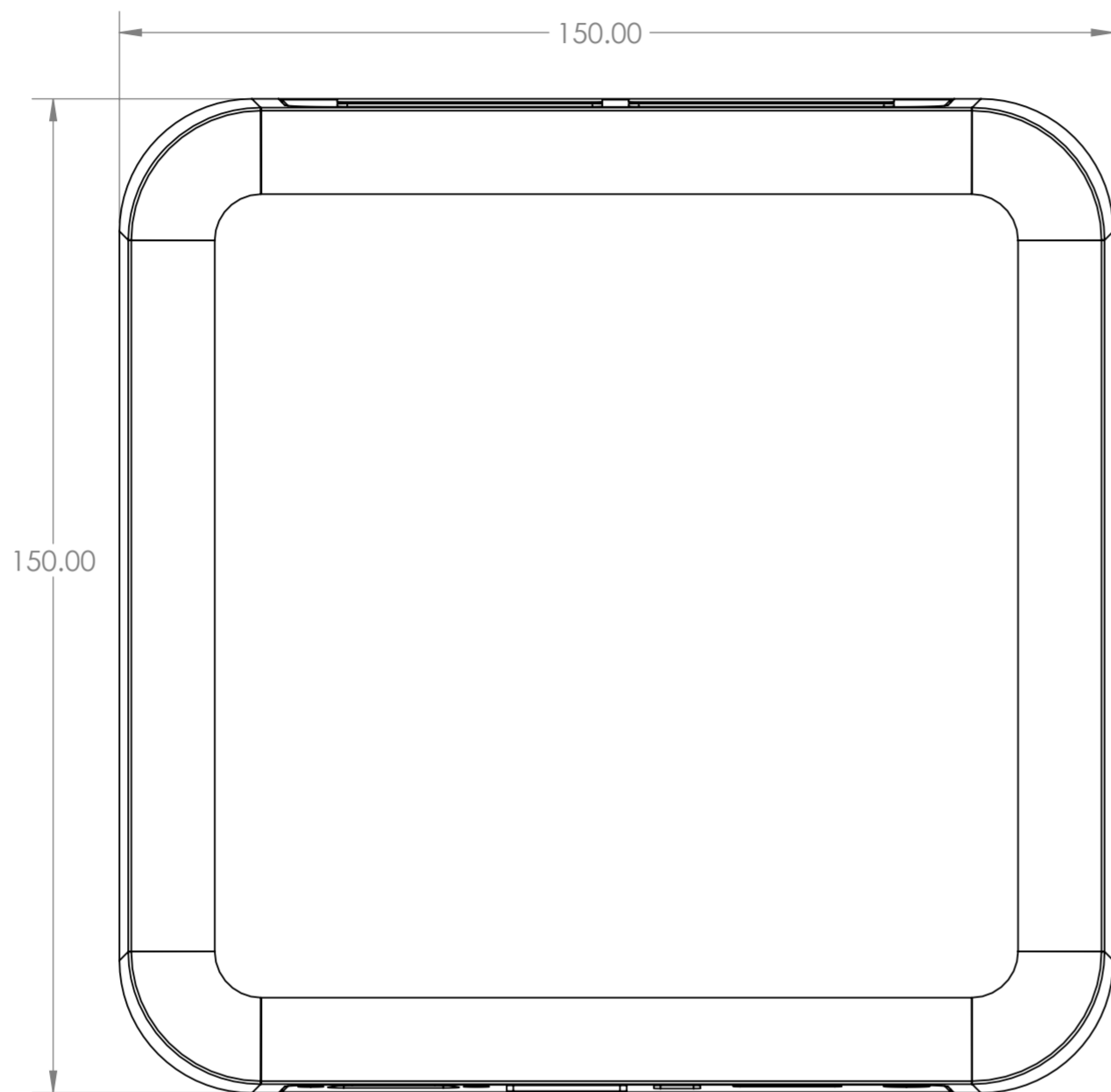
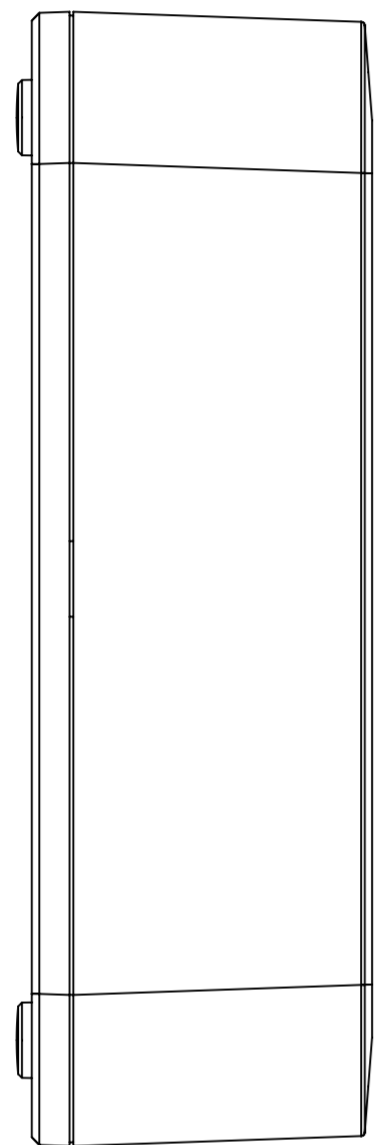
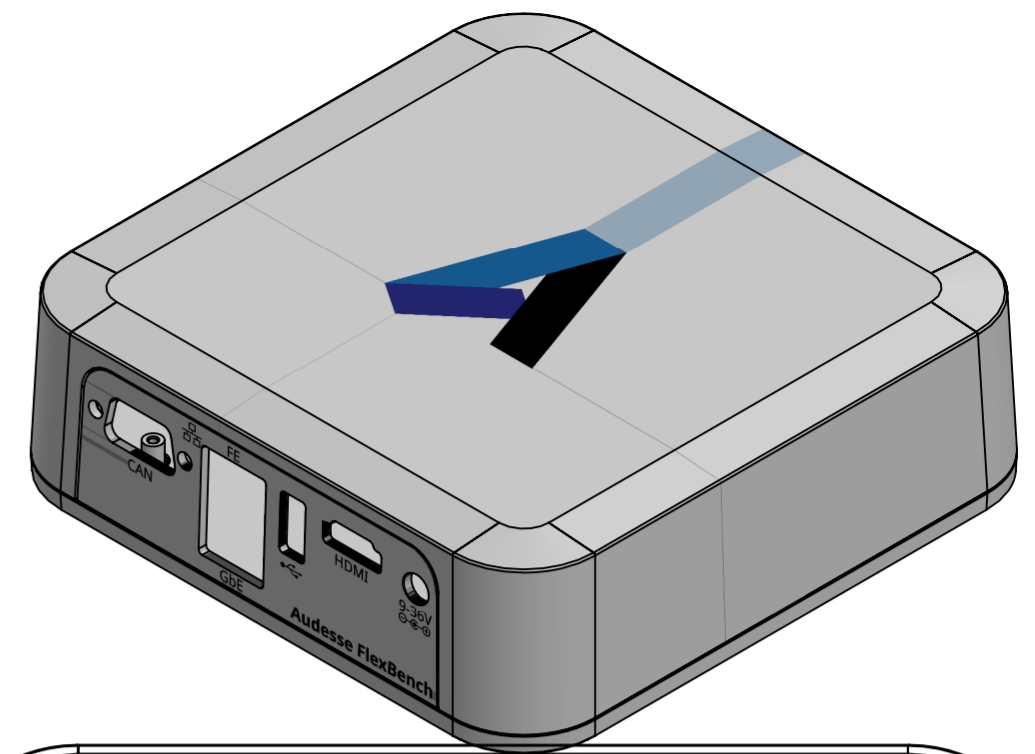
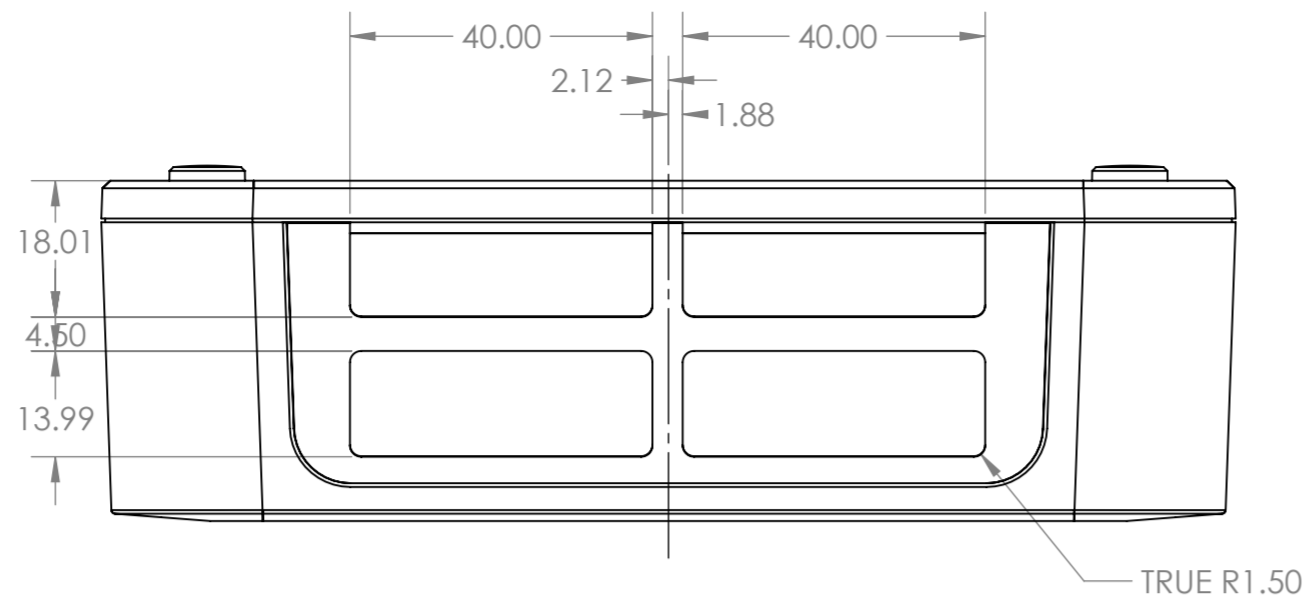
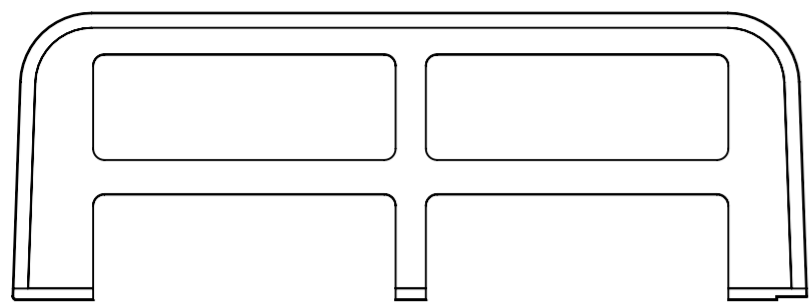

UNLESS OTHERWISE SPECIFIED: DIMENSIONS ARE IN MILLIMETERS			FINISH:		DEBURR AND BREAK SHARP EDGES		DO NOT SCALE DRAWING		REVISION	
TOLERANCES: LINEAR: ANGULAR:										
DRAWN	NAME	SIGNATURE	DATE					TITLE: Audesse FlexBench PF15-5-15W		
CHK'D	RM							DWG NO. Drawing V2		A2
APP'VD								SCALE: 1:1		
MFG								SHEET 1 OF 1		
Q.A								WEIGHT:		

12 11 10 9 8 7 6 5 4 3 2 1